

## SAFEMASTER Interface Module HC 3096N, HL 3096N



### Your Advantages

- Simple contact extension and re-inforcement also of safety modules
- Cost and space saving alternative compared to contactors
- Simple contact monitoring via forcibly guided NC contact
- large wire cross section 0.5 - 2.5 mm<sup>2</sup> (12-24 AWG) reduces thermal load on wires

### Features

- According to DIN EN 61810-1, IEC 60664-1, IEC/EN 60 947-5-1
- With forcibly guided contacts according to IEC 61810-3
- Models with soldered in or plug-in PCB safety relay consisting of:
  - plug in socket HC 3096N and safety relay OA 5611
  - plug in socket HL 3096N and safety relay OA 5612
- With polarity protected diode
- Optionally with free-wheeling diode across A1+ and A2
- Optionally AgNi + 0,2 µm Au or AgNi + 5 µm Au
- For DIN rail mounting according IEC/EN 60715
- HC 3096N: width 18 mm
- HL 3096N: width 36 mm

### Approvals and Markings



### Circuit Diagrams

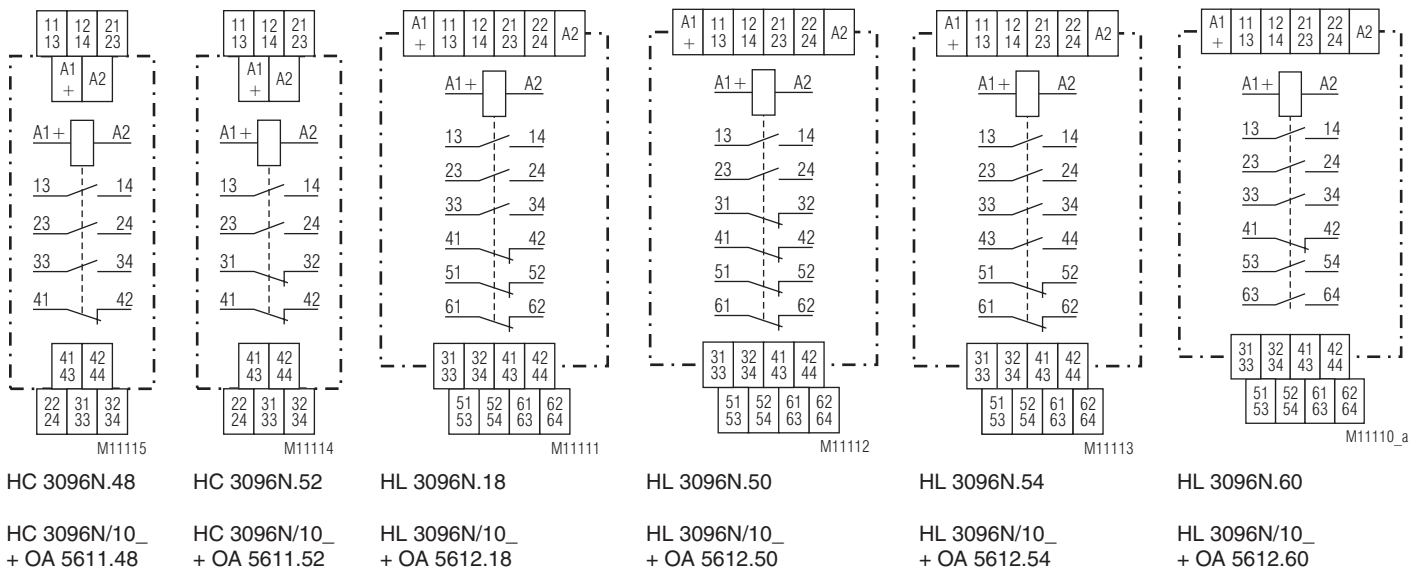

### Connection Terminals

Terminal designation	Signal designation
A1+	L / +
A2	N / -
41, 42 / 61, 62	NC contact
All other contacts see relevant circuit diagram	NC contacts / or NO contacts

## Technical Data

### Input

<b>Nominal voltage <math>U_N</math>:</b>	DC 24, 60, 110 V other voltages on request
<b>Voltage range:</b>	0.8 ... 1.1 $U_N$
<b>Nominal consumption</b>	
HC 3096N:	0.6 W
HL 3096N:	0.8 W
HL 3096N.50:	1.0 W

### Output

<b>Contacts:</b>	
HC 3096N.52, OA 5611.52:	2 NO and 2 NC contacts
HC 3096N.48, OA 5611.48:	3 NO and 1 NC contacts
HL 3096N.18, OA 5612.18:	3 NO and 3 NC contacts
HL 3096N.50, OA 5612.50:	2 NO and 4 NC contacts
HL 3096N.54, OA 5612.54:	4 NO and 2 NC contacts
HL 3096N.60, OA 5612.60:	5 NO and 1 NC contacts
<b>Contact material:</b>	AgNi + 0,2 $\mu$ m Au, AgNi + 5 $\mu$ m Au other on request

<b>Contact type:</b>	spring contact
<b>Operate time:</b>	typical 20 ms
<b>Release time:</b>	typical 6 ms
<b>Measured nominal voltage:</b>	AC 250 V

### Thermal current $I_{th}$

HC 3096N:	3 x 5 A
HL 3096N:	4 x 5 A

### Switching capacity

to AC 15		
NO contact:	3 A / AC 230 V	IEC/EN 60 947-5-1
NC contact:	2 A / AC 230 V	IEC/EN 60 947-5-1
to DC 13		
NO contact:	2 A / DC 24 V	IEC/EN 60 947-5-1
NC contact:	2 A / DC 24 V	IEC/EN 60 947-5-1
according to DC 13		
NO contact:	4 A / 24 V at 0.1 Hz	
NC contact:	4 A / 24 V at 0.1 Hz	

### Electrical life

HC 3096N	
to AC 230 V / 5 A $\cos\phi = 1$ :	$\geq 2 \times 10^5$ switching cycles

HL 3096N	
at DC 24 V / 5 A ohmic:	$\geq 2 \times 10^5$ switching cycles

### Permissible switching

<b>frequency:</b>	10 switching cycles / s
-------------------	-------------------------

### Short circuit strength

<b>max. fuse rating:</b>	6 A gG / gL	IEC/EN 60 947-5-1
--------------------------	-------------	-------------------

<b>Mechanical life:</b>	$\geq 50 \times 10^5$ switching cycles
-------------------------	--

### General Data

<b>Operating mode:</b>	Continuous operation
------------------------	----------------------

### Temperature range:

Operation:	- 40 ... + 55 °C
------------	------------------

Storage:	- 25 ... + 70 °C
----------	------------------

<b>Relative air humidity:</b>	93 % at 40 °C
-------------------------------	---------------

<b>Altitude:</b>	< 2.000 m
------------------	-----------

### Clearance and creepage distances

rated impulse voltage /  
pollution degree

Input / output

HC devices:	6 kV / 2	IEC 60 664-1
-------------	----------	--------------

HL devices:	4 kV / 2	IEC 60 664-1
-------------	----------	--------------

output / output:	4 kV / 2	IEC 60 664-1
------------------	----------	--------------

Overvoltage category:

Insulation test voltage,

type test: 2,5 kV; 1 min

### EMC

Electrostatic discharge:	8 kV (air)	IEC/EN 61 000-4-2
--------------------------	------------	-------------------

HF-irradiation

80 MHz ... 1 GHz:	20 V / m	IEC/EN 61 000-4-3
-------------------	----------	-------------------

1 GHz ... 2,7 GHz:	10 V / m	IEC/EN 61 000-4-3
--------------------	----------	-------------------

Fast transient:	4 kV	IEC/EN 61 000-4-4
-----------------	------	-------------------

Surge voltages

between

wires for power supply:	1 kV	IEC/EN 61 000-4-5
-------------------------	------	-------------------

between wire and ground:	2 kV	IEC/EN 61 000-4-5
--------------------------	------	-------------------

HF-wire guided:	10 V	IEC/EN 61 000-4-6
-----------------	------	-------------------

Interference suppression:	Limit value class B	EN 55 011
---------------------------	---------------------	-----------

## Technical Data

### Degree of protection

Housing:	IP 40	IEC/EN 60 529
----------	-------	---------------

Terminals:	IP 20	IEC/EN 60 529
------------	-------	---------------

**Housing:** Thermoplastic

**Vibration resistance:** Amplitude 0.35 mm

Frequency 10 ... 55 Hz, IEC/EN 60 068-2-6

Humid heat IEC/EN 60 068-2-30

### Climate resistance:

**Terminal designation:** EN 50 005

**Wire connection:** 0.5 ... 2,5 mm<sup>2</sup> solid

0.5 ... 2,5 mm<sup>2</sup> flexible

Captive slotted screw

**Mounting:** DIN rail

**Weight** IEC/EN 60 715

HC 3096N: approx. 71 g

HL 3096N: approx. 90 g

### Dimensions

#### Width x height x depth

HC 3096N: 18 x 106 x 65 mm

HL 3096N: 36 x 106 x 65 mm

### UL Data

**Nominal voltage  $U_N$ :** DC 6 ... 110 V

### Switching capacity:

Ambient temperature 60 °C: Pilot duty B300

5 A 250Vac G. P.

5 A 24Vdc

0.4 A 250Vac resistive

**Wire connection:** 60°C / 75°C copper conductors only

AWG 24 - 12 torque value 4.4 lb-in



Technical data that is not stated in the UL-Data, can be found in the technical data section.

### Classification to DIN EN 50155

#### Vibration and

**shock resistance:** Category 1, Class B IEC/EN 61 373

**Ambient temperature:** T1, T2, T3 and TX compliant

**Voltage range:** 0.7 ... 1.25  $U_N$  with operational limitations

**Protective coating of the PCB:** No

### Standard Types

HC 3096N.48/400 DC 24 V

Article number: 0066000

• 3 NO, 1 NC contact

• AgNi + 0.2  $\mu$ m Au

• Width: 18 mm

HL 3096N.54/400 DC 24 V

Artikelnummer: 0066040

• 4 NO, 2 NC contact

• AgNi + 0.2  $\mu$ m Au

• Width: 36 mm

### Ordering Example

H\_3096N.\_.\_ / \_.\_ /61 DC 24 V

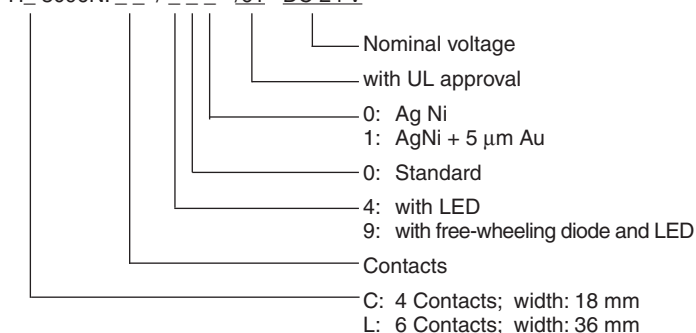

## Variants

Plug in socket  
H\_ 3096N /102:

Plug in socket with  
free-wheeling diode and LED  
Plug in socket with LED

H\_ 3096N /103:

further variants on request

## Ordering example for variants

H\_ 3096N / 10 \_ /61 DC 24 V

Nominal voltage  
with UL-approval  
2: Plug in socket with  
free-wheeling diode and LED  
3: Plug in socket with LED  
0: Standard  
1: Plug in socket  
C: 4 Contacts; width: 18 mm  
L: 6 Contacts; width: 36 mm

## Characteristic

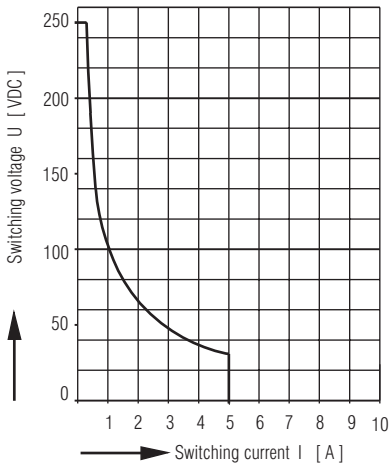

Safe switch of, no standing arc  
max. 1 switching cycle / s

## Arc limit curve under resistive load

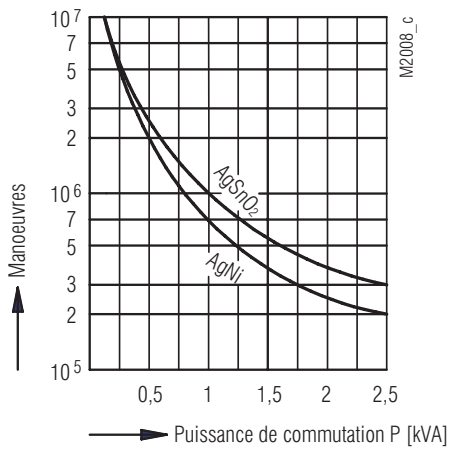

## Contact service life

## Connection example for HC 3096N/10\_/61

Relay: OA 5611.52  $\cong$  2 NO contacts and 2 NC contacts (Standard)

Terminal	Contact	Contact-type	Connection
11, 13, 12, 14	1	NO contact	13, 14
21, 23, 22, 24	2	NO contact	23, 24
41, 43, 42, 44	3	NC contact	31, 32
31, 33, 32, 34	4	NC contact	41, 42

The terminal assignment is according to the diagram on the installed relay

## Connection example for HC 3096N/10\_/61

Relay: OA 5612.18  $\cong$  3 NO contacts and 3 NC contacts (Standard)

Terminal	Contact	Contact-type	Connection
11, 13, 12, 14	1	NO contact	13, 14
21, 23, 22, 24	2	NO contact	23, 24
41, 43, 42, 44	3	NO contact	33, 34
31, 33, 32, 34	4	NC contact	41, 42
51, 53, 52, 54	5	NC contact	51, 52
61, 63, 62, 64	6	NC contact	61, 62

The terminal assignment is according to the diagram on the installed relay



## Safety Notes



**Dangerous voltage.**  
Electric shock will result in death or serious injury.



Disconnect all power supplies before servicing equipment.

- Faults must only be removed when the relay is disconnected
- The user has to make sure that the device and corresponding components are installed and wired according to the local rules and law (TUEV, VDE, Health and safety).
- Installation work must only be done when power is disconnected.

Dimensions with safety relay

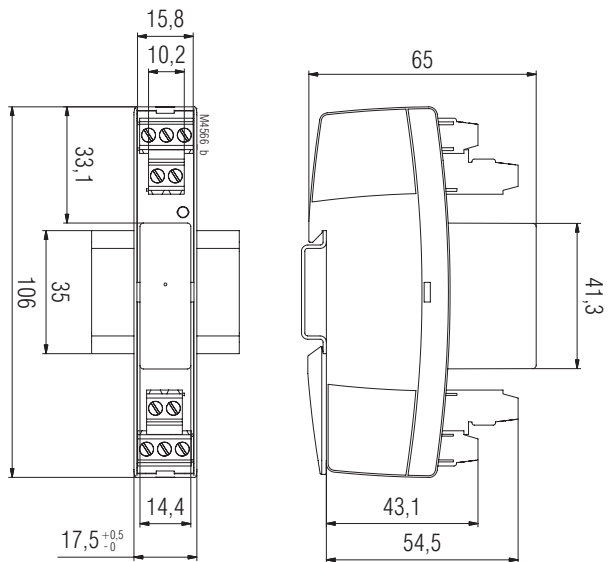

HC 3096N

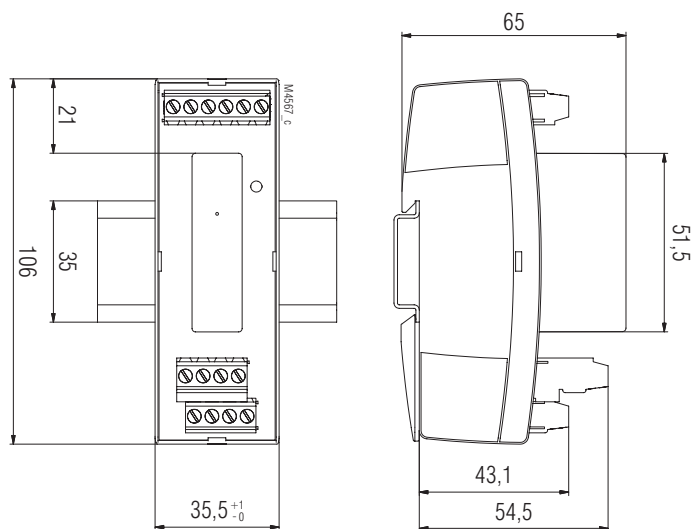

HL 3096N

Dimensions with plug in socket

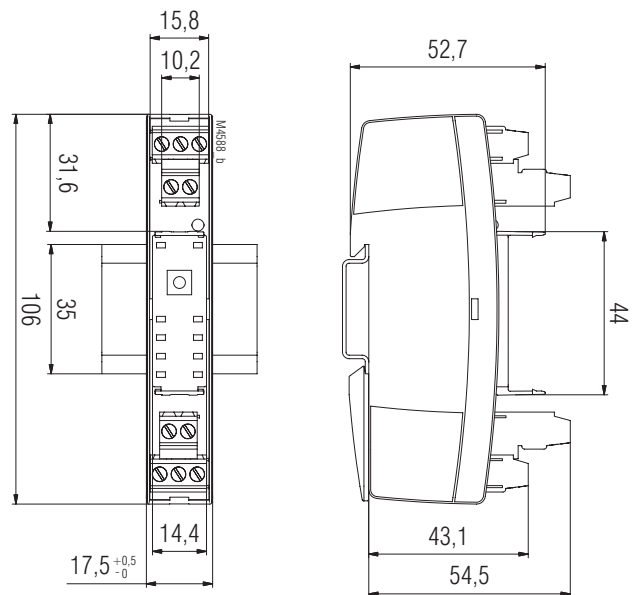

HC 3096N

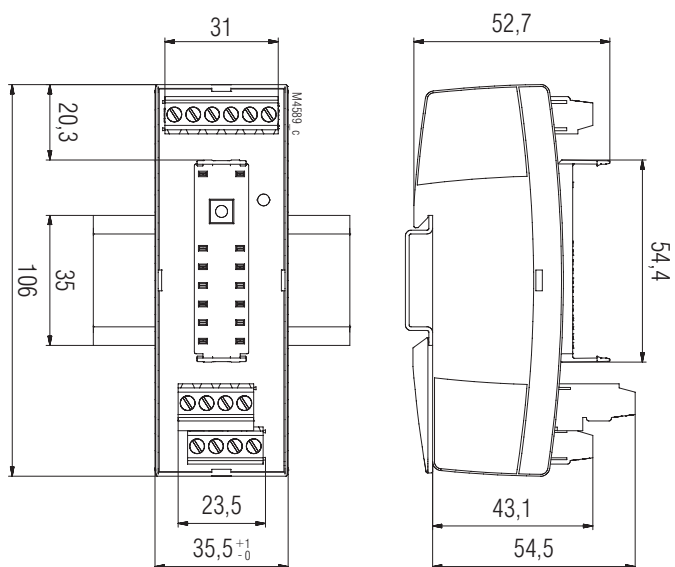

HL 3096N